



METROVAL
Controle de Fluidos Ltda.



OVAL GEAR METERS

MANUAL

OVAL DOUBLE CASE GEAR METERS
MANTEINANCE AND REPAIR MANUAL

Address:
Rua Christiano Kilmeyers, 819
13.460-000 - Nova Odessa - S.P.

P.O. Box: 170
E-mail: vendas@metroval.com.br
http://www.metroval.com.br

Telephone: ++55 19 3466-5859
Fax: ++55 19 3466-7579



METROVAL

Controle de Fluidos Ltda.



TABLE OF CONTENTS

	Page
1 - INSTALLATION.....	3
1.1 - HANDLING.....	3
1.2 - OPERATIONAL DATA.....	3
1.3 - INSTALLATION IN THE PIPELINE.....	3
1.4 - METER'S MEASURING CHAMBER.....	3
1.5 - STRAINER.....	3
1.6 - PIPE CLEANING.....	3
1.7 - REMOVING THE PROTECTION COVERS.....	3
1.8 - FLOW DIRECTION.....	4
2 - METER ASSEMBLY IN THE PIPELINE.....	4
2.1 - CORRECT ASSEMBLY POSITIONS.....	4
2.2 - PIPELINE MECHANICAL TENSIONS.....	5
2.3 - JOINTS.....	5
3 - FILLING THE SYSTEM WITH LIQUID.....	5
3.1 - SLOW STARTUP.....	5
4 - STARTUP.....	5
4.1 - BEGINNING TO OPERATE.....	5
4.2 - HIGH VISCOSITY LIQUIDS THAT NEED PREVIOUS HEATING.....	5
5 - MANTEINANCE.....	5
5.1 - CHECKING THE TRANSMISSION.....	5
5.1.1 - Low pressure meter (CLASS 300).....	6
5.1.2 High pressure meter (CLASS 600).....	6
5.2 - REPLACING PARTS.....	6
5.3 - METER'S HOUSING MANTEINANCE.....	7
5.3.1 - Magnetic Coupling.....	7
5.3.2 - Opening the meter's housing.....	8
5.3.3 - Wet gearbox check.....	8
5.4 - OPENING THE MEASURING CHAMBER.....	8
5.4.1 - For the types ODC 10, 50, 125, 600 and 1200.....	8
5.4.2 - For the type ODC 250.....	9
5.5 - VISUAL INSPECTION OF THE MEASURING CHAMBER.....	9
5.6 - MANTEINANCE AND REPLACEMENT OF OVAL GEARS.....	9
5.7 - MANTEINANCE AND REPLACEMENT OF THE SHAFTS.....	9
5.8 - INSPECTION AND REPLACEMENT OF THE LOWER GRAPHITE PLATES.....	10
5.9 - INSPECTION AND REPLACEMENT OF THE UPPER GRAPHITE PLATES.....	10
5.10 - REMOVING THE MEASURING CHAMBER.....	10
6 - PUTTING THE METER OFF SERVICE.....	11
6.1 - SPARE PARTS.....	11



1 - INSTALLATION

1.1 - HANDLING

The meter should be handled with care during transportation, storage and installation.

1.2 - OPERATIONAL DATA

Observe the operational data specified on the Identification Plate on the meter.

Attend to the order specifications and to the data sheet.

In case of changing of the operational data, contact Metroval informing the meter's serial number and model.

1.3 - INSTALLATION IN THE PIPELINE

Install the Oval Gear Meter (1) in the pipeline after the pump (2).

1.4 - METER'S MEASURING CHAMBER

Install the Oval Gear Meter (1) in the system in a way that the Measuring Chamber is always filled with liquid during stops and when the pump is turned off. If necessary, install a drain valve (6).

1.5 - STRAINER

To protect the Meter against damage caused by solids install a Strainer (4) (mesh=0.25mm), before the meter.

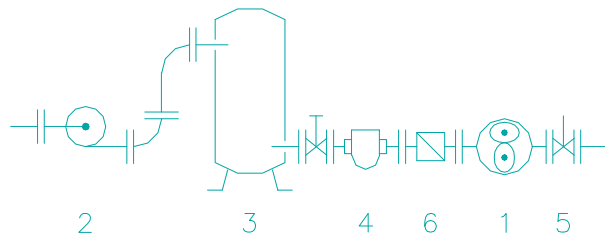

1.6 - PIPE CLEANING

Clean the piping in order to remove all solid particles. Wash the piping installing a flanged piece of pipe (2) instead of the Meter (1), to avoid damaging it.

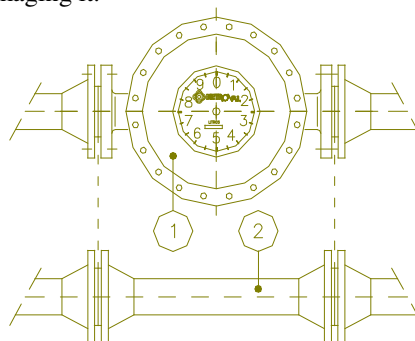

1.7 - REMOVING THE PROTECTION COVERS

Remove the protection covers from the Meter's flanges just before the installation.

Ensure that no solid particles penetrate the Oval Gear Meter during installation.



1.8 - FLOW DIRECTION

Install the Meter in a way that the arrow in the Meter Housing (1) points towards the same direction of the line's flow direction.

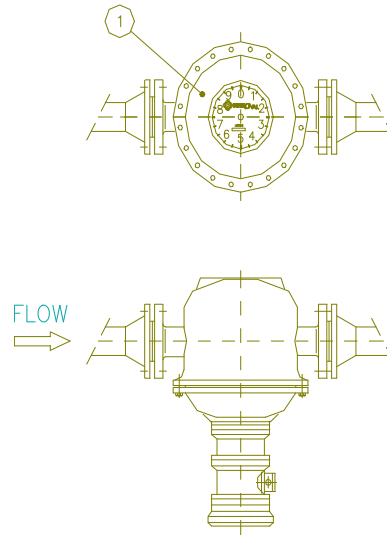

2 - METER ASSEMBLY IN THE PIPELINE

2.1 - CORRECT ASSEMBLY POSITIONS

The Oval Gear Meter can be installed vertically or horizontally.

IMPORTANT: The Shafts and the Oval Gears must be on the horizontal position, otherwise, the equipment will be damaged.

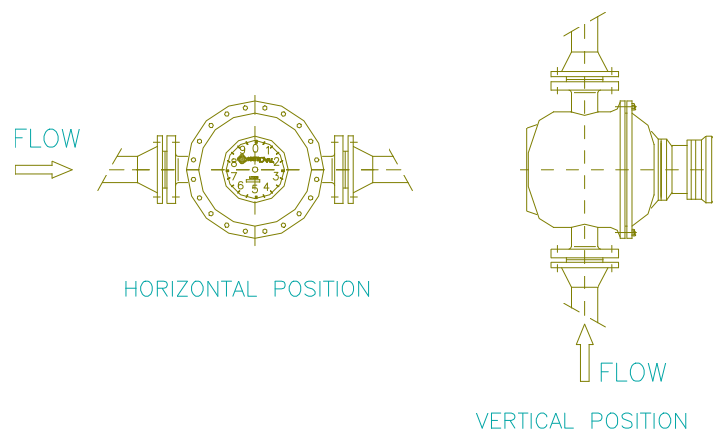

WARNING: Never install the Oval Gear Meter as shown in the figure below.

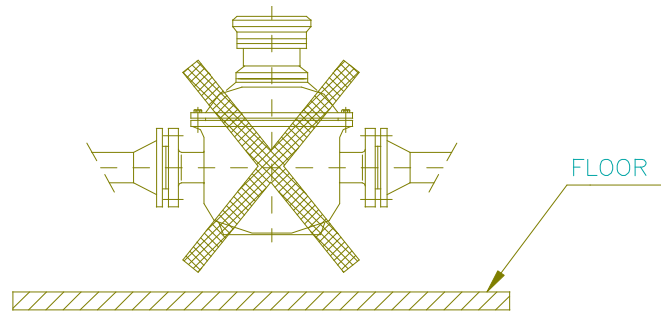

2.2 - PIPELINE MECHANICAL TENSIONS

Install the Oval Gear Meter free of pipeline mechanical tensions.

2.3 - JOINTS

Use joints that are compatible to the liquid being measured. The joints shouldn't be wider than the pipe section.

3 - FILLING THE SYSTEM WITH LIQUID

3.1 - SLOW STARTUP

Fill the system slowly, with the valve after the Meter closed, then slowly open the valve after the Meter.

4 - STARTUP

4.1 - BEGINNING TO OPERATE

The Oval Gear Meter is now ready to work. When operating for the first time, open the valve slowly.

4.2 - HIGH VISCOSITY LIQUIDS THAT NEED PREVIOUS HEATING.

Previously heat the Meter, the strainer and the piping before starting to work with high viscosity liquids that need previous heating.

5 - MAINTENANCE

The Oval Gear Meter doesn't require any regular maintenance.

Under severe work conditions, we recommend an inspection and calibration every year. If this inspection reveals an unacceptable rise in the Meter's error, the following parts may be worn out, so they must be checked. To do so, there's no need to remove the Meter from the line, because these parts have no contact with the liquid.

IMPORTANT: If by any reason the Meter must be sent to Metroval for technical assistance it must be drained and DECONTAMINATED before shipment.

5.1 - CHECKING THE TRANSMISSION

IMPORTANT: The Meter series FA is divided in to two pressure classes: low (CLASS 300) and high (CLASS 600). The only thing that differs the two classes is the housing with the transmission set. This part is used only in the high pressure meters (CLASS 600).



5.1.1 - Low pressure meter (CLASS 300)

To check the couplings (1) remove the bolts (2) and manually check if the couplings (1) are turning freely. If this not occurs in the transmission proceed according to 5.2. If the housing coupling is jammed proceed according to 5.3.

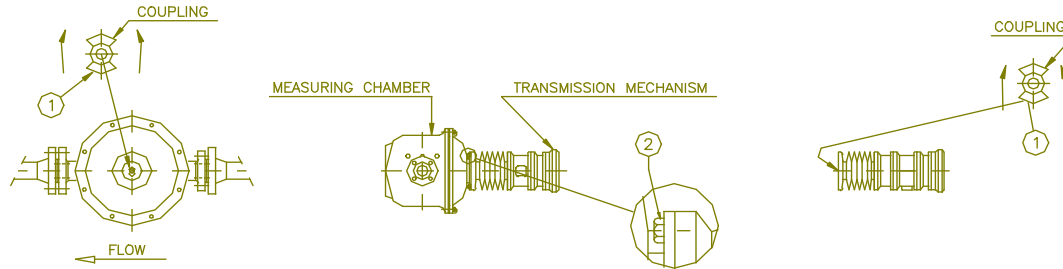

5.1.2 High pressure meter (CLASS 600)

To check the couplings (1) remove the bolts (2) and manually check if the couplings (1) are turning freely. If this not occurs in the transmission proceed according to 5.2. If the housing coupling is jammed proceed according to 5.3.

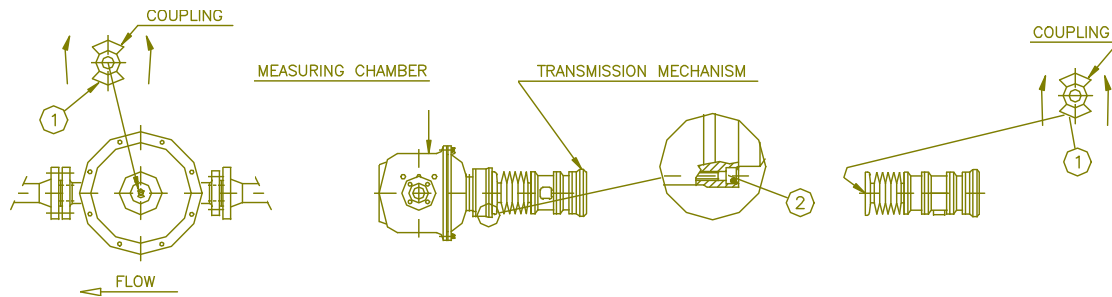

5.2 - REPLACING PARTS

If the transmission mechanism is jammed, it must be disassembled and checked manually, to assure that each section coupling turns freely. When the malfunction is located at one of the sections, the following parts can be replaced:

PULSE GENERATOR AG19/AG20

PARTS

- 1- BALL BEARING
- 2- CORRECTION GEAR
- 3- COUPLING
- 4- VANE DISC

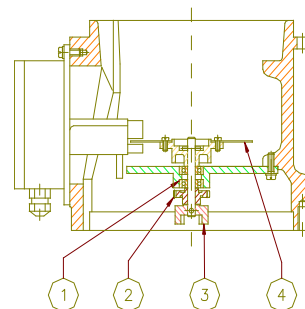



HEAT EXCHANGER

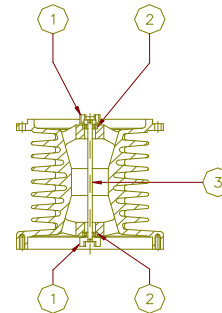

PARTS

- 1- COUPLING
- 2- BALL BEARING
- 3- SHAFT

HOUSING WITH TRANSMISSION SET

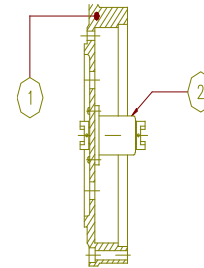

PARTS

- 1- RING
- 2- TRANSMISSION SET (must be compatible with work temperature)

This section is used in high pressure meters only

5.3 - METER'S HOUSING MAINTENANCE

To perform the meter's housing (1) maintenance, it's necessary to remove it from the line, drain and decontaminate it.

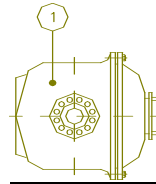

5.3.1 - Magnetic Coupling

After removing the meter from the line and decontaminate it, remove the bolts (1) to release the pressure plate (3). After that, pull out the magnetic coupling (2) and ensure that it's not jammed. If this happens, it will be necessary to replace it or send it to Metroval for technical assistance.

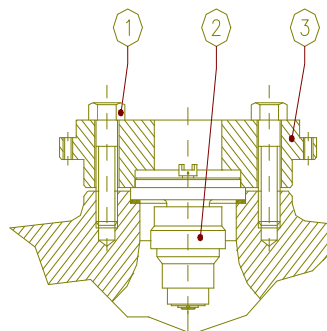



5.3.2 - Opening the meter's housing

To open the meter's housing (4) it's necessary to remove the bolts (1), the cover (2), and the gasket (3).

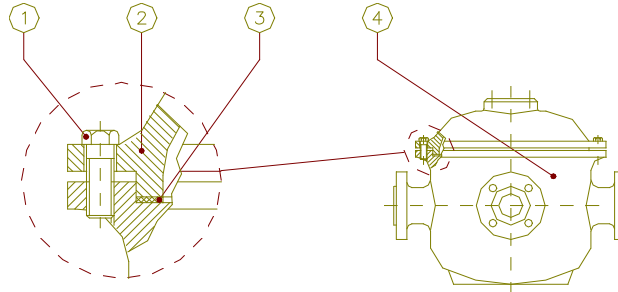

5.3.3 - Wet gearbox check

After removing the housing cover, check the wet gearbox.

Release the coupling gear (1) washer (2) and the intermed. Gear (3) washer (2), then check if the bearings or teeth are worn out. If there's anything wrong with these parts they must be replaced.

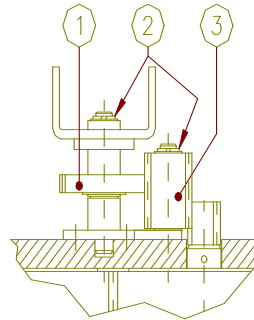

5.4 - OPENING THE MEASURING CHAMBER

5.4.1 - For the types ODC 10, 50, 125, 600 and 1200

Remove the bolts (1), placing two of them in the free screws, according to the table below, in order to remove the measuring chamber cover (2).

The meters contain upper plates pressed at the measuring chamber cover (2).

Meter	Bolt
ODC10	M6
ODC50	M6
ODC125	M8
ODC600	M12
ODC1200	M16

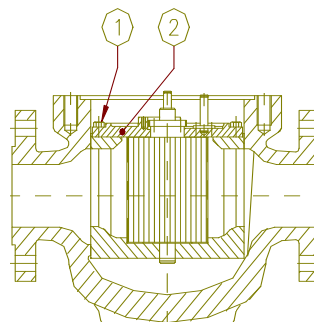



5.4.2 - For the type ODC 250

Remove the bolts (4), the bearing cover (5) and the bolts (6) to remove the uniform motion gear (7). Be careful when removing it, because it contains two tapered pins (2). After removing the the uniform motion gear (7), remove the bolts (1) and screw two M12 bolts at the chamber cover (3) at the same time, in order to remove it.

Note: The meters contain two upper plates pressed at the measuring chamber cover (3).

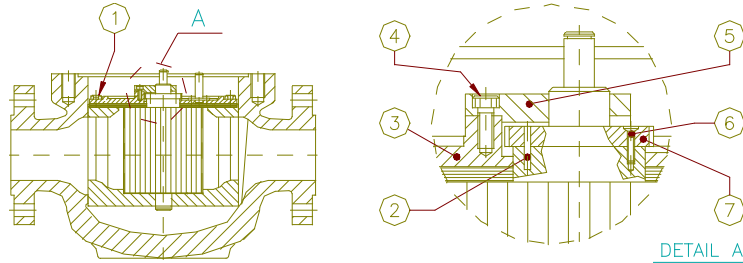

5.5 - VISUAL INSPECTION OF THE MEASURING CHAMBER

Once the measuring chamber (1) is opened as described above, it's interior must be visually inspected. Remove the Oval Gears and place them on some soft surface.

Note: Read item 5.6 about the Oval Gears.

Look for scratched or worn out areas at the bottom or at the walls of the measuring chamber (1). A uniform surface indicates na instrument in perfect working conditions.

If anything wrong is found inspecting the measuring chamber (1) the meter must be sent for technical assistance at Metroval.

About the shafts (3,4) read item 5.7.

About the lower graphite plates, read item 5.8.

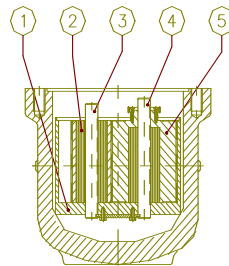

5.6 - MANTEINANCE AND REPLACEMENT OF OVAL GEARS

Any maintenance of the oval gears must be done by Metroval's technical assistance department.

If the gears can't be recovered, they must be replaced by new ones.

5.7 - MANTEINANCE AND REPLACEMENT OF THE SHAFTS

To perform maintenance at the shafts (2,3) the measuring chamber (1) must be removed, because the axis are held in position by a locking plate (5).

After removing the measuring chamber (1) according to item 5.10, remove the bolts (4) and release the locking plate (5) to remove the shaft manually.

Note: The measuring chamber should not be removed if the shafts are in good conditions.

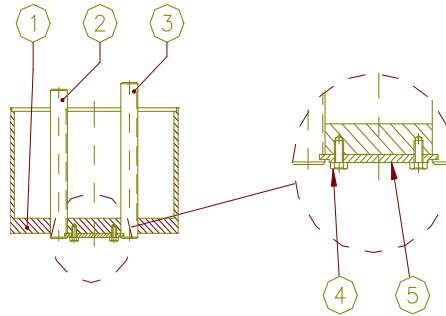

5.8 - INSPECTION AND REPLACEMENT OF THE LOWER GRAPHITE PLATES

After removing the oval gears, check for deep scratches at the lower graphite plates (2). If these scratches are found, the lower graphite plates (2) must be replaced as described below.

To remove the lower graphite plates (2) located at the bottom of the measuring chamber (1), hold tight one of the plates while injecting air in the openings between them.

If the method described above doesn't work, the lower graphite plates (2) must be destroyed.

ATTENTION!! Be careful not to damage the bottom of the measuring chamber (1) when breaking the lower graphite plates (2).

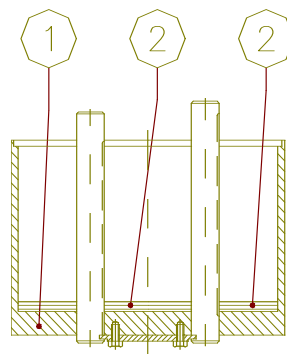

5.9 - INSPECTION AND REPLACEMENT OF THE UPPER GRAPHITE PLATES

The upper graphite plates must be examined in the same way as the lower graphite plates, looking for any damage, excessively worn out areas or deep scratches. If any of those are found it's necessary to replace the plates.

5.10 - REMOVING THE MEASURING CHAMBER

To remove the measuring chamber (2) from the meter's body (3), remove the bolts (1) at the external part of the body (3).

After removing the bolts (1), pull up the measuring chamber (2). To do so, use two of the bolts that hold the measuring chamber cover.

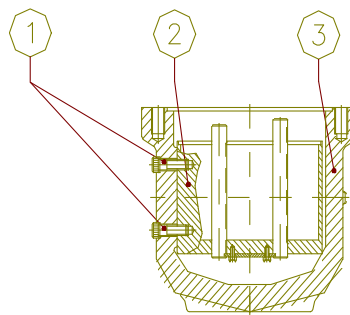



METROVAL
Controle de Fluidos Ltda.



IMPORTANT: After assembling the meter with the measuring chamber (2), a pressure test must be performed to ensure that there is no leakage.

6 - PUTTING THE METER OFF SERVICE

If the Oval Gear Meter is taken off service for a long period of time it should be fully cleaned and conserved with acid - free oil.

Both flanges must be sealed for protection.

The Oval Gear Meter must be stored in a dry place.

6.1 - SPARE PARTS

When asking for the spare parts list please mention your meter's serial number.